

Compact, Dual LCD Display Digital Pressure Sensor

■ Features

- Pressure measurement of any gas, liquid or oil [Fluid type] (※except substances which may corrode stainless steel 316L)
- Simultaneous display of present value (PV) and set value (SV) (※Selectable SV, pressure unit, or none display for SV display part)
- Selectable NPN, PNP open collector output by parameter setting
- 3 colors for PV display part (run mode: red or green / setting mode: orange)
- 12-segment LCD display for easier value reading
- Measurement range: -100.0 to 100.0kPa, -100 to 1,000kPa (pneumatic type: compound pressure, fluid type: sealed gauge pressure)
- Analog output: voltage (1-5VDC), current (DC4-20mA)
- Parameter copy function
- Option input/output: auto shift, remote zero, hold (only for PSQ-□C□□U-□)
- Forced output control mode for device testing and maintenance
- Min. display unit: 0.1kPa, 1kPa (variable by model)
- One-touch connector type for easy wiring and maintenance
- Password setting for SV



Pneumatic type



Fluid type

⚠ Please read "Safety Considerations" in the instruction manual before using.



■ Ordering Information

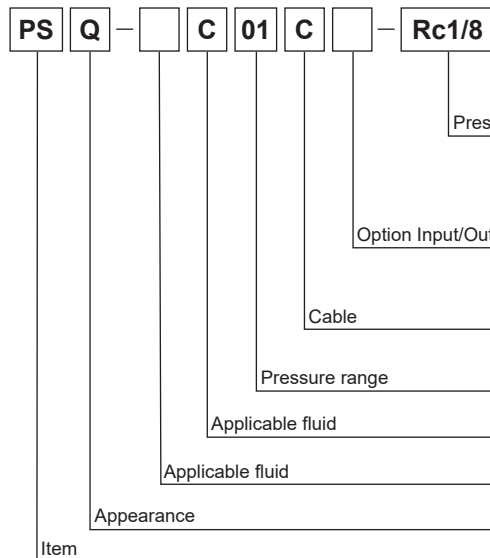

Applied fluid	Pneumatic type	Fluid type
Pressure port		
Rc1/8	●	●
R1/8	●	●
NPT1/8	●	—
R1/4	—	●
NPT1/4	—	●
9/16-18UNF	—	●
No mark	NPN or PNP open collector output	
U	NPN or PNP open collector output + analog output or external input type	
No mark	Cable type	
C	Connector type	
01	100kPa	
1	1,000kPa	
C	Compound pressure	
No mark	Pneumatic type (air, non-corrosive gas)	
B	Fluid type (gas, liquid, oil)	
Q	Regular square type (30×30mm), dual display	
PS	Pressure Sensor	

■ Pressure Conversion Chart

from to	Pa	kPa	MPa	kgf/cm ²	mmHg	mmH ₂ O	psi	bar	inHg
1Pa	1	0.001	0.000001	0.000010197	0.007501	0.101972	0.000145038	0.00001	0.0002953
1kPa	1000.000	1	0.001	0.010197	7.500617	101.971626	0.145038	0.01	0.2953
1MPa	1000000	1000	1	10.197162	7500.61683	101971.626	145.038243	10	295.299875
1kgf/cm ²	98066.5	98.0665	0.098067	1	735.55924	10000.0005	14.223393	0.980665	28.959025
1mmHg	133.322368	0.133322	0.000133	0.001359	1	13.595099	0.019337	0.001333	0.039370
1mmH ₂ O	9.80665	0.009807	—	0.000099	0.073556	1	0.00142	0.000098	0.002896
1psi	6894.733	6.89473	0.006895	0.070307	51.714752	703.016716	1	0.068947	2.036014
1bar	100000.0	100.0000	0.100000	1.019716	750.062	10197.1626	14.503824	1	29.529988
1inHg	3386.388	3.386388	0.003386	0.034532	25.40022	345.315507	0.491156	0.033864	1

E.g.) For calculating 760mmHg to kPa : According to above chart, 1mmHg is 0.133322kPa, therefore 760mmHg will be 760×0.133322kPa=101.32472kPa.

SENSORS

CONTROLLERS

MOTION DEVICES

SOFTWARE

(A) Photoelectric Sensors

(B) Fiber Optic Sensors

(C) LIDAR

(D) Door/Area Sensors

(E) Vision Sensors

(F) Proximity Sensors

(G) Pressure Sensors

(H) Rotary Encoders

(I) Connectors/ Cables/ Sensor Distribution Boxes/ Sockets

PSQ Series



■ Pressure and Max. Pressure Display Range

Type	MPa	kPa	kgf/cm ²	bar	psi	mmHg	inHg	mmH ₂ O
Compound pressure	—	-100.0 to 100.0 (-101.3 to 110.0)	-1.020 to 1.020 (-1.033 to 1.122)	-1.000 to 1.000 (-1.013 to 1.100)	-14.50 to 14.50 (-14.70 to 15.95)	-750 to 750 (-760.0 to 825.1)	-29.5 to 29.5 (-29.91 to 32.48)	-102.0 to 102.0 (-103.3 to 112.2)
	—	-100 to 1000 (-101 to 1100)	-1.020 to 10.20 (-1.030 to 11.22)	-1.000 to 10.00 (-1.01 to 11.00)	-14.50 to 145.0 (-14.65 to 159.5)	-750 to 7500 (-757.6 to 8251)	-29.5 to 295 (-29.83 to 324.8)	-102.0 to 1020 (-103.0 to 1122)

※() is Max. pressure display range.

※For using mmH₂O unit, multiply display value by 100.

■ Specifications

Pressure type		Gauge pressure (In case of fluid type, standard pressure are sealed gauge pressure ^{※1})					
Type		NPN or PNP open collector output type			NPN or PNP open collector output+ analog output or external input type		
Model		PSQ-□C01□-□		PSQ-□C1□-□		PSQ-□C01□U-□	
Rated pressure range		-100.0 to 100.0kPa		-100 to 1,000kPa		-100.0 to 100.0kPa	
Display&Setting pressure range		-101.3 to 110.0kPa		-101 to 1,100kPa		-101.3 to 110.0kPa	
Min. display unit		0.1kPa		1kPa		0.1kPa	
Max. pressure range	Pneumatic type	2 times of rated pressure		1.5 times of rated pressure		2 times of rated pressure	
	Fluid type	3 times of rated pressure					
Applied fluid		<ul style="list-style-type: none"> • Pneumatic type: air, non-corrosive gas • Fluid type: air, non-corrosive gas and fluid that do not corrode stainless steel 316L 					
Power supply		12-24VDC≡ (ripple P-P: max. 10%)					
Allowable voltage range		90 to 110% of rated voltage					
Current consumption		Max. 50mA			Max. 50mA (analog output: max. 70mA)		
Control output		NPN or PNP open collector output · Load voltage: max. 30VDC≡ · Load current: max. 100mA · Residual voltage: max. 2VDC≡					
Hysteresis ^{※2}		Min. display interval					
Repeat error		±0.2% F.S. ± min. display interval					
Response time		Select one: 2.5ms, 5ms, 10ms, 25ms, 50ms, 100ms, 250ms, 500ms, 1,000ms, 5,000ms					
Protection circuit		Output short over current protection circuit					
Analog output ^{※3}	Voltage output	—				<ul style="list-style-type: none"> • Output voltage: 1-5VDC≡ ±2.5% F.S. • Linear: max. ±1% F.S. • Resolution: 1/2,000 • Output impedance: approx. 240Ω • Response time: 50ms 	
	Current output	—				<ul style="list-style-type: none"> • Output current: DC4-20mA ±2.5% F.S. • Linear: max. ±1% F.S. • Resolution: 1/2,000 • Output impedance: approx. 100kΩ • Response time: 50ms 	
External input ^{※3} (Auto shift/Remote zero/Hold)		—				<ul style="list-style-type: none"> • ON voltage: max. 0.4VDC≡ • OFF voltage: 5-Vin or open • Resolution: 1/2,000 • Output impedance: approx. 100kΩ 	
Display digits		Present value (PV) display part, setting value (SV) display part: 4-digit					
Display method		12-segment LCD method					
Min. display interval	MPa	0.001		0.001		0.001	
	kPa	0.1		1		0.1	
	kgf/cm ²	0.001		0.01		0.001	
	bar	0.001		0.01		0.001	
	psi	0.02		0.2		0.02	
	mmHg	1		—		1	
	inHg	0.1		—		0.1	
	mmH ₂ O	0.1		—		0.1	
Display accuracy		0 to 50°C: max. ±0.5% F.S., -10 to 0°C: max. ±1% F.S.					
Insulation resistance		Over 50MΩ (at 500VDC megger)					
Dielectric strength		1,000VAC 50/60Hz for 1min					
Vibration		1.5mm amplitude at frequency of 10 to 55Hz (for 1min) in each X, Y, Z direction for 2 hours					
Environment	Ambient temp.	-10 to 50°C, storage: -20 to 60°C					
	Ambient humi.	30 to 80%RH, storage: 30 to 80%RH					
Cable (fluid type)		Ø4mm, 5-wire, 3m (AWG24, core diameter: 0.08mm, number of cores: 40, insulator out diameter: Ø1mm)					
Protection structure		• Pneumatic type: IP40 (IEC standard)			• Fluid type: IP65 (IEC standard)		
Material		<ul style="list-style-type: none"> • Pneumatic type - Front case: polycarbonate, rear case: polycarbonate, pressure port: brass-nickel plated • Fluid type - Front case: polycarbonate, rear case: polyamide 6, pressure port: stainless steel 316L 					
Approval		 					
Weight ^{※4}		• Pneumatic type: approx. 165g (approx. 80g)			• Fluid type: approx. 210g (approx. 125g)		

※1: The unit is sealed structure. It is based on atmospheric pressure 101.3kPa.

※2: In hysteresis output mode, it is variable.

※3: Select one between analog output (voltage or current) and external input.

※4: The weight includes packaging. The weight in parenthesis is for unit only.

※For using mmH₂O unit, multiply display value by 100.

※Environment resistance is rated at no freezing or condensation.

Compact, Dual LCD Display Digital Pressure Sensor

Unit Description

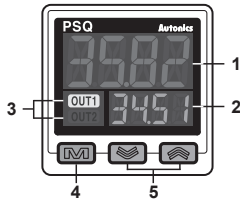

1. **Present value (PV) display part (green, red, orange by setting/status)**
 RUN mode: Displays PV.
 Setting mode: Displays parameter.
2. **Setting value (SV) display part (green)**
 RUN mode: Displays setting value, unit, etc.
 Setting mode: Displays SV.
3. **Output indicator (OUT1, OUT2) (orange):** Turns ON while the control output turns ON.
4. **M key**
 RUN mode: Press the **M** key for over 2 sec to enter parameter 1 group.
 Press the **M** key for over 4 sec to enter parameter 2 group.
 Setting mode: Press the **M** key to select the setting items.
 Press the **M** key for over 2 sec to return RUN mode.
5. **M+, M- key**
 RUN mode: Press the **M+**, **M-** key to set preset value of output operation mode.
 Press the **M+**, **M-** keys to set key lock/unlock.
 Press the **M+**, **M-** keys to adjust zero point.
 Press the **M+**, **M-** keys to set peak hold.
 Preset value setting mode: Press the **M+**, **M-** key to increase/decrease setting value.
 Setting mode: Changes the parameter.

Dimensions

⊙ Pneumatic type

(unit: mm)

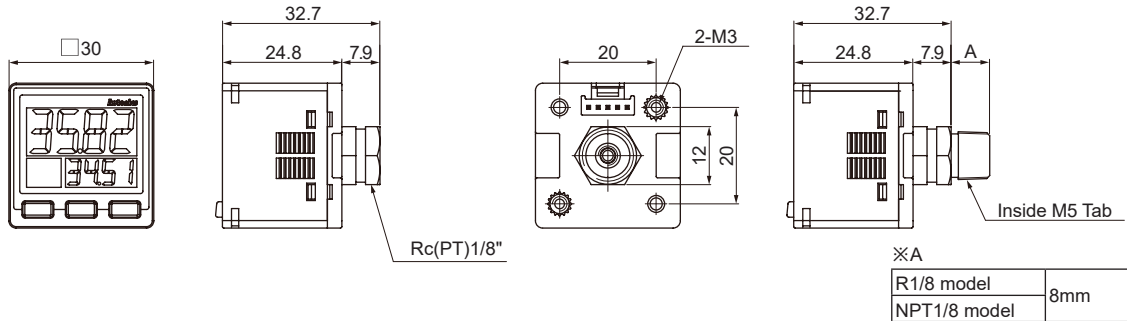

⊙ Fluid type

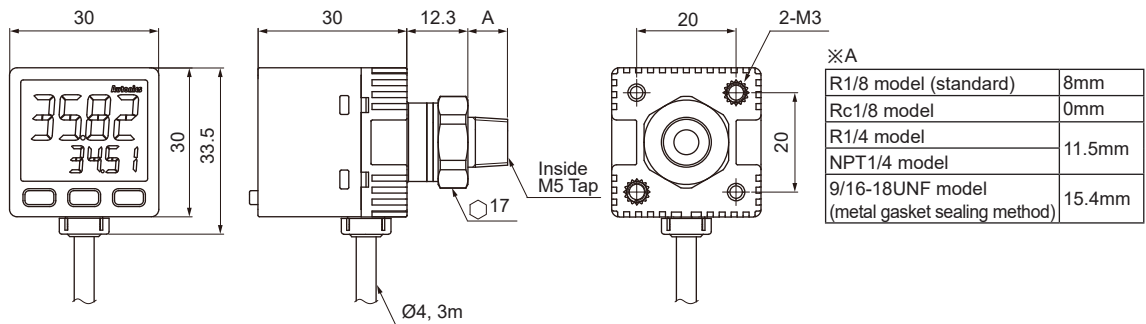

⊙ Accessory

● Connector cable (PSO-C01, Pneumatic/Fluid type)

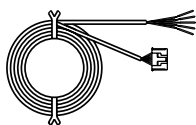

※ \varnothing 4mm, 5-wire, 2m
 (AWG24, core diameter: 0.08mm,
 number of cores: 40,
 insulator diameter: \varnothing 1mm)

SENSORS

CONTROLLERS

MOTION DEVICES

SOFTWARE

(A) Photoelectric Sensors

(B) Fiber Optic Sensors

(C) LIDAR

(D) Door/Area Sensors

(E) Vision Sensors

(F) Proximity Sensors

(G) Pressure Sensors

(H) Rotary Encoders

(I) Connectors/
 Connector Cables/
 Sensor Distribution
 Boxes/ Sockets

PSQ Series

■ Dimensions

◎ Accessory

(unit: mm)

● Bracket A (Pneumatic type)

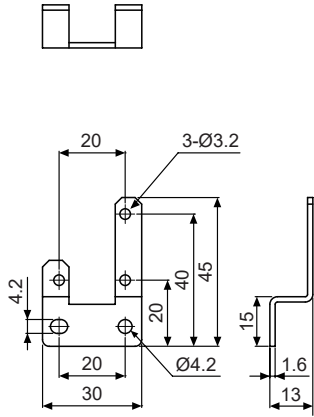

● Bracket B (Pneumatic type)

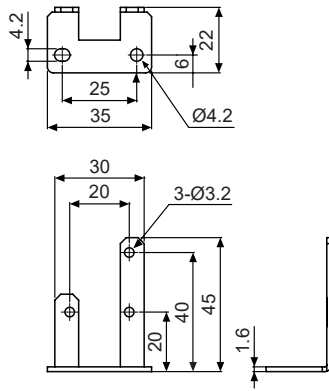

● Bracket C (Fluid type)

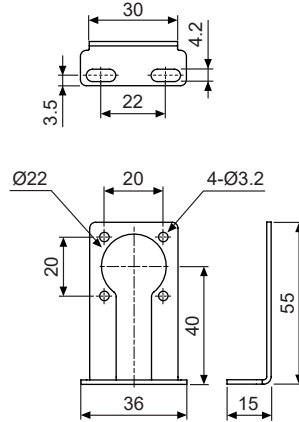

◎ Sold separately

● Integrated installation set (Pneumatic/Fluid type)

· Front cover (PSO-P01)

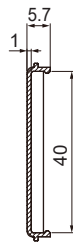
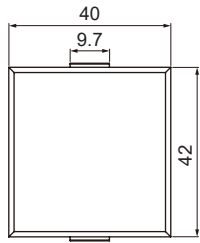

· Panel bracket (PSO-B02)

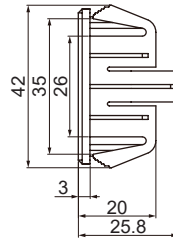
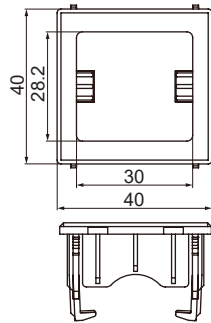

· Panel cut-out

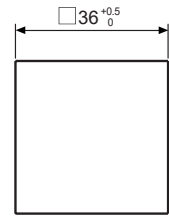

(panel thickness 0.8 to 3.5mm)

● Separate installation set (Pneumatic type)

· Front cover (PSO-P02)

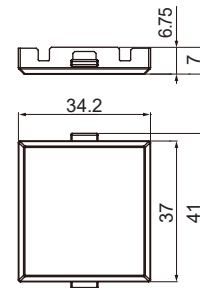

· Front/Rear panel bracket set (PSO-B04)

<Front panel bracket>

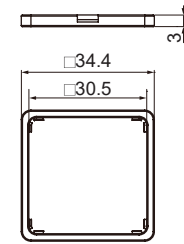

<Rear panel bracket>

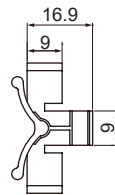
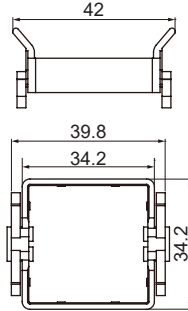

· Panel cut-out

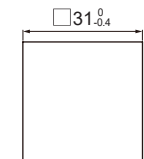

(panel thickness: 0.5 to 7mm)

<When 'N' units are installed in series>

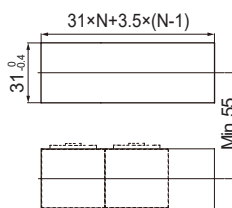

● M5 gendur (PSO-Z01, Pneumatic type)



Compact, Dual LCD Display Digital Pressure Sensor

Input/Output Circuit and Connections

⊙ NPN open collector output type

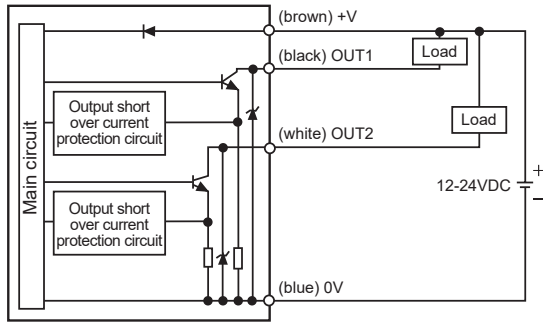

⊙ PNP open collector output type

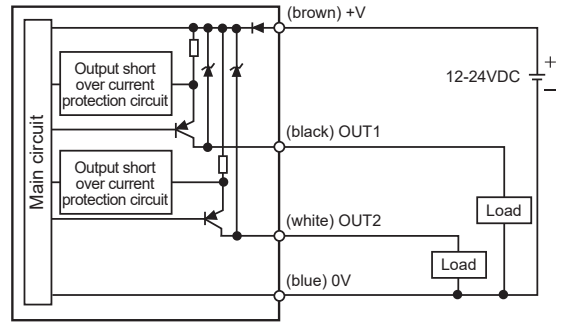

⊙ NPN open collector output+ analog output or external input type

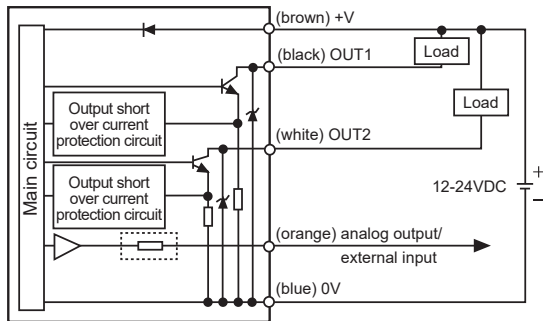

※ : output impedance

⊙ PNP open collector output+ analog output or external input type

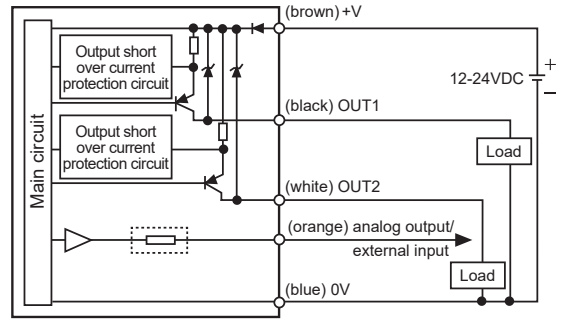

※ : output impedance

Setting for Each Mode

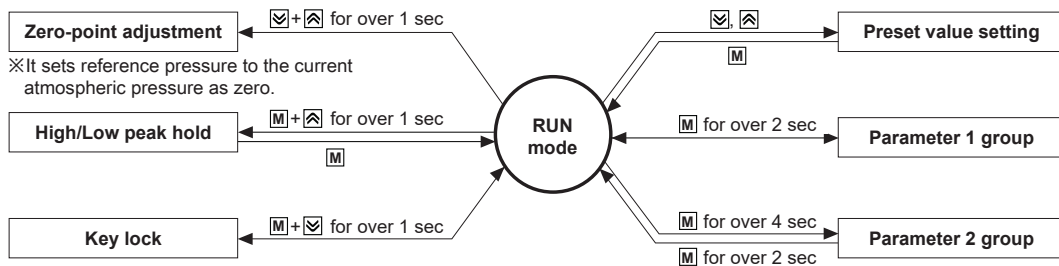

Zero-point Adjustment

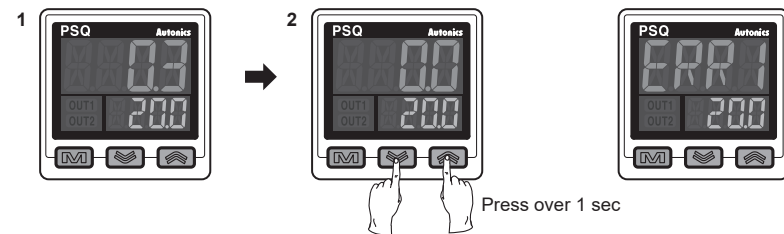

※If executing zero-point adjustment when external pressure over $\pm 5\%$ of rated pressure is applied, **ERR 1** flashes five times during pressing the keys. Remove external pressure and execute zero point again.

- To set zero atmospheric pressure forcibly, press the + keys over 1 sec in RUN mode with the opened pressure port.
- Zero point adjustment is completed, the PV display part displays 0.0 .

※Please execute zero-point adjustment regularly.

SENSORS

CONTROLLERS

MOTION DEVICES

SOFTWARE

(A) Photoelectric Sensors

(B) Fiber Optic Sensors

(C) LIDAR

(D) Door/Area Sensors

(E) Vision Sensors

(F) Proximity Sensors

(G) Pressure Sensors

(H) Rotary Encoders

(I) Connectors/ Connector Cables/ Sensor Distribution Boxes/ Sockets

PSQ Series

Parameter Setting

- ※After entering parameter 1/2 group, if there is no additional key input for 60 sec, it maintains previous setting value and it returns to RUN mode.
- ※Press the **[M]**, **[R]** key to set the setting value.
- ※After entering parameter 1/2 group, press the **[M]** key for over 2 sec to return to RUN mode.
- ※When pressing the **[M]** key once returning RUN mode from parameter 1 group, 2 group within 2 sec, it enters the previous parameter group.
- ※Some parameters are activated/deactivated according to the setting of other parameters. Refer to the description of each parameter.

Parameter Group

Parameter 1 group						
Parameter name		Setting range		Description	Factory default	
oUt 1	OUT1 operation mode	ER5Y HY5M WIN	Easy Hysteresis Window comparison	Select OUT1 operation mode. ※When setting OUT1 operation mode as auto sensitivity setting mode [AUt o] or forced output control mode [FoUt], OUT2 operation mode is set automatically same as the setting value of OUT1 operation mode.	ER5Y	
oUt 2	OUT2 operation mode	oFF ER5Y HY5M WIN	OFF Easy Hysteresis Window comparison	Select OUT2 operation mode.	oFF	
I/o *1	Analog output/ External input	R-V R-C SHFt ZERo HoLd	Analog voltage output Analog current output Auto shift Remote zero Hold	Select analog output/external input operation mode. Auto shift: When reference pressure of the pressure sensor changes, it corrects present pressure to reference pressure and by moving detection level as much as fluctuation level. Remote zero: It is the same function as auto shift but remote zero makes the measured pressure as 0 forcibly. Hold: The function to hold present value (PV) and control output while signal is input. ※When OUT1 operation mode is set as [FoUt] or applied pressure is higher/lower than the display pressure range, auto shift [SHFt], remote zero [ZERo] functions are not available.	R-V	
SHoLd *1	Auto shift applied terminal	oUt 1 oUt 2 ALL	OUT1 OUT2 OUT1 & OUT2	Select auto shift applied terminal. ※Appears when Analog output/External input is [SHFt].	oUt 1	
ZERo *1	Remote zero applied terminal	oUt 1 oUt 2 ALL	OUT1 OUT2 OUT1 & OUT2	Select remote zero applied terminal. ※Appears when analog output/external input is [ZERo].	oUt 1	
NoNC	Output type		OUT1	OUT2	No	
		No	Normally Open	OFF		※Appears when OUT2 operation mode is [oFF].
		NC	Normally Closed	OFF		
		Io2o	Normally Open	Normally Open		※Appears when OUT1 operation mode is [AUt o], or OUT2 operation mode is [HY5M], [WIN].
		Io2C	Normally Closed	Normally Open		
		IC2o	Normally Closed	Normally Open		
IC2C	Normally Closed	Normally Closed				
SPd	Response time	2.5, 5, 10, 25, 50, 100, 250, 500, 1000, 5000		It can prevent control output from chattering by changing response time. ※If the response time is getting longer, the detection will be more stable but present value (PV) might be different from the real pressure value.	2.5	
ELoR	PV display color	R-oN G-oN REd GREn	Normal: Green / Output: Red Normal: Red / Output: Green Fixed red Fixed green	Select the present value (PV) display and the color linked output.	R-oN	
dI SP	Color linked output	oUt 1 oUt 2 ALL	OUT1 OUT2 OUT1 & OUT2	Select the color linked output. ※Appears when OUT2 operation mode is not [oFF] and PV display color is set as [R-oN] and [G-oN].	oUt 1	
UNI t	Display unit	kPa MPa kgf/cm ² bar psi mmHg inHg mmH ₂ O		Select the display unit. ※For using mmH ₂ O unit, multiply display value by 100.	kPa	

*1: Appears only in NPN or PNP open collector output + analog output or external input model.

Compact, Dual LCD Display Digital Pressure Sensor

Parameter Setting

Parameter 2 group				Factory default						
Parameter name	Setting range	Description		Factory default						
SV display part	Standard Unit OFF	Select the display type at the SV display part in RUN mode. Standard [Std]: Display setting value (SV) always. Unit [Unit]: Display pressure unit normally. When pressing [M]+[H] key, display setting value (SV) for 5 sec. None [FF]: It does not display any value normally. When pressing [M]+[H] key, display setting value (SV) for 5 sec. ※If select unit [Unit] or None [FF], changing setting value (SV) is available when setting value is displayed.		Std						
Parameter copy	OFF ON ON with key lock	This function is for copying parameter settings of Master to Slave 1:1. ※For the details, refer to '■ Functions - ○ Parameter Copy'.		FF						
Parameter reset	FF Reset parameter setting	Reset the parameter settings.		FF						
Password	0000 to 9999	Set the 4-digit password. [0000]: Disable password [0001]: Only checking parameters		0000						
Control output switching	NPN PNP	Select type of control output.		NPN						
Hysteresis for easy mode	Bar type (Min: 1ea, Max: 8ea)	Set the hysteresis for easy mode. <table border="1"> <thead> <tr> <th>Rated pressure range</th> <th>Hysteresis per 1 Bar</th> </tr> </thead> <tbody> <tr> <td>-100.0 to 100.0kPa</td> <td>0.1kPa</td> </tr> <tr> <td>-100.0 to 1,000kPa</td> <td>1kPa</td> </tr> </tbody> </table> ※Appears when OUT1 or OUT2 operation mode is easy mode. ※Although the display unit is changed, standard unit of hysteresis for easy mode is not changed.		Rated pressure range	Hysteresis per 1 Bar	-100.0 to 100.0kPa	0.1kPa	-100.0 to 1,000kPa	1kPa	!!!
Rated pressure range	Hysteresis per 1 Bar									
-100.0 to 100.0kPa	0.1kPa									
-100.0 to 1,000kPa	1kPa									

High/Low Peak Hold

This function is to diagnose malfunction of the system caused by parasitic pressure through memorizing input the max./min. pressure occurred from the system.

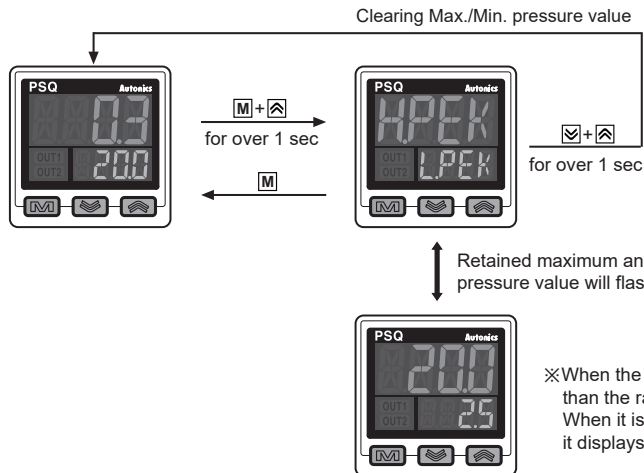

※Clearing Max./Min. pressure value.

1. Press the [M]+[H] key for over 1 sec in RUN mode and set the peak hold.
2. High peak is displayed on present value (PV) display, and low peak is displayed on setting value (SV) display.
3. Press the [M]+[H] key for over 1 sec, initialize high/low peak value.

※When the memorized Max. pressure is higher than the rated pressure, it displays HHHH. When it is lower than the rated pressure, it displays LLLL.

Analog Output Scale Adjustment

• only for NPN or PNP open collector output+analog output or external input type model

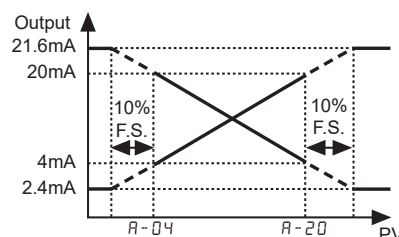
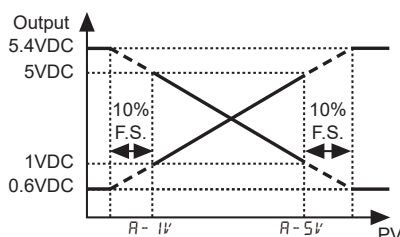

■ Preset Setting

◎ Setting guide

- To enter the preset setting mode, press the \checkmark , \boxtimes key in RUN mode.
- Press the \checkmark , \boxtimes key to change preset value, the M key to move to the next mode.
- If there is no additional key or the M key input for over 2 sec during setting, the value is automatically set and it returns to RUN mode. (except forced output control mode)

●NPN or PNP open collector output(OUT1/2)

1. Select OUT1/2 operation mode [OUT 1/2] to use in parameter 1 group.
(OUT1/2 operation mode: easy, hysteresis, window comparison, auto sensitivity setting, forced output control)
2. Enter the preset setting mode from RUN mode.
(set items are displayed in the order of OUT1 - OUT2)
3. Set the value for each item.

• Setting example

OUT1: Hysteresis mode
OUT2: Window comparison mode

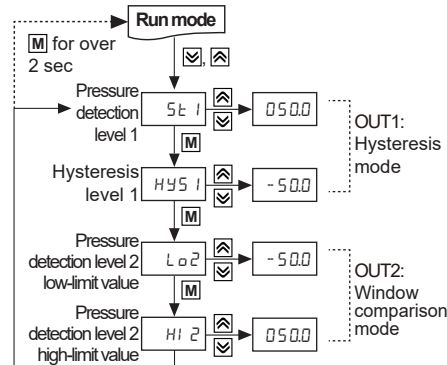

●Analog output/External input

1. Select analog output/external input mode [I / O] to use in parameter 1 group.
(Analog output/external input: analog voltage output, analog current output, auto Shift, remote zero, hold)
2. Enter the preset setting mode from RUN mode.
(analog output/external input items are displayed after OUT1 - OUT2)
3. Set the value for each item.

• Setting example

Analog current output scale

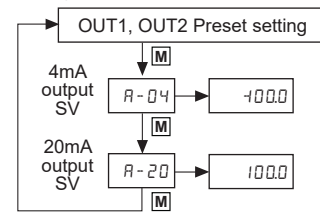

●Note

- Setting items and setting value are displayed at the setting value (SV) display part alternatively.
- Operation mode (easy, hysteresis, window comparison, auto sensitivity setting) that can be set separately per each output (OUT1/OUT2) display parameter name with identification number.([St 1]: [St 1]/[St 2])
- When changing pressure unit or analog output/external input, the preset value is initialized corresponding to changed item.
- When changing operation mode, the preset value is reset for the changed mode.

●Preset setting by output operation mode

Output operation mode	Preset	Setting range	Factory default	
			-100.0 to 100.0kPa	-100 to 1,000kPa
ERASY Easy	P Pressure detection level	Min. display pressure < [P] ≤ Max. display pressure	05.00	05.00
HYSM Hysteresis	St Pressure detection level	Min. display pressure < [St] ≤ Max. display pressure	05.00	05.00
	HYS Hysteresis level	Min. display pressure ≤ [HYS] < [St]	-5.00	00.00
WIN Window comparison	Lo Pressure detection level low-limit	Min. display pressure ≤ [Lo] ≤ Max. display pressure - (3 × min. display unit)	-5.00	00.00
	Hi Pressure detection level high-limit	[Lo] + (3 × min. display unit) ≤ [Hi] ≤ Max. display pressure	05.00	05.00
AUTO Auto sensitivity setting	St 1 Pressure detection level 1	Min. display pressure ≤ [St 1] ≤ Max. display pressure - 1% of rated pressure	-5.00	00.00
	St 2 Pressure detection level 2	[St 1] + 1% of rated pressure ≤ [St 2] ≤ Max. display pressure	05.00	05.00
	SEt Pressure detection level	$SEt = \frac{(St 1 + St 2)}{2}$, [St 1] ≤ [SEt] ≤ [St 2] Pressure detection level [SEt] can be selectable by pressing the \checkmark , \boxtimes key.	00.00	02.50
FoUt Forced output control	—	—	—	—
R-V Analog voltage output	R-1V 1V output SV	0% F.S. ≤ [R-1V] ≤ 100% F.S.	100.0	00.00
	R-5V 5V output SV	[R-1V] + 10% F.S. ≤ [R-5V] ≤ 100% F.S. or 0% F.S. ≤ [R-5V] ≤ [R-1V] - 10% F.S.	100.0	10.00
R-C Analog current output	R-04 4mA output SV	0% F.S. ≤ [R-04] ≤ 100% F.S.	100.0	00.00
	R-20 20mA output SV	[R-04] + 10% F.S. ≤ [R-20] ≤ 100% F.S. or 0% F.S. ≤ [R-20] ≤ [R-04] - 10% F.S.	100.0	10.00

Compact, Dual LCD Display Digital Pressure Sensor

■ Preset Setting

● Preset setting by external input mode

External input mode		Preset		Setting range	Factory default
<i>S H F t</i>	Auto shift	<i>S H I N</i>	Auto shift correction value*	Min. preset setting value < [<i>S H I N</i>] < Max. preset setting value	0000
<i>Z E R o</i>	Remote zero	<i>Z E I N</i>	Remote zero correction value*	Min. preset setting value < [<i>Z E I N</i>] < Max. preset setting value	0000
<i>H o L d</i>	Hold	—	—	—	—

※Apply 0VDC to orange cable over 1ms to operate auto shift or remote zero mode.

※Press the + for over 1 sec to delete set auto shift correction.

◎ Supported operation mode list

NPN or PNP open collector output		OUT1		OUT2	
<i>E R S Y</i>	Easy	<i>o F F</i>	OFF	<i>o F F</i>	OFF
		<i>E R S Y</i>	Easy	<i>E R S Y</i>	Easy
		<i>H Y S M</i>	Hysteresis	<i>H Y S M</i>	Hysteresis
		<i>W I N</i>	Window comparison	<i>W I N</i>	Window comparison
<i>H Y S M</i>	Hysteresis	<i>o F F</i>	OFF	<i>o F F</i>	OFF
		<i>E R S Y</i>	Easy	<i>E R S Y</i>	Easy
		<i>H Y S M</i>	Hysteresis	<i>H Y S M</i>	Hysteresis
		<i>W I N</i>	Window comparison	<i>W I N</i>	Window comparison
<i>W I N</i>	Window comparison	<i>o F F</i>	OFF	<i>o F F</i>	OFF
		<i>E R S Y</i>	Easy	<i>E R S Y</i>	Easy
		<i>H Y S M</i>	Hysteresis	<i>H Y S M</i>	Hysteresis
		<i>W I N</i>	Window comparison	<i>W I N</i>	Window comparison
<i>A U t o</i>	Auto sensitivity setting				
<i>F o U t</i>	Forced output control				

Analog output*	
<i>R - V</i>	Analog voltage output
<i>R - I</i>	Analog current output

External input*	
<i>S H F t</i>	Auto shift
<i>Z E R o</i>	Remote zero
<i>H o L d</i>	Hold

※Analog output (voltage or current) and external input (auto shift/remote zero/hold) are not available at the same time.

■ Output Operation Mode

※PSQ Series has 5 output operation mode. Use the proper operation mode in accordance with the desired application of detection.

◎ Easy mode [*E R S Y*]

- Set the hysteresis of pressure detection automatically.
- Set the pressure detection level [*P 1*, *P 2*].

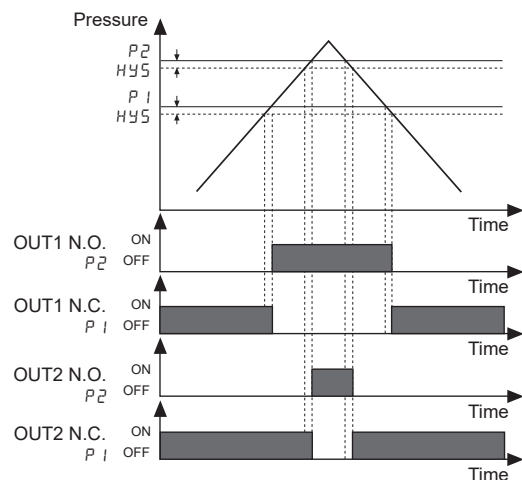

※It is possible to set the hysteresis value in hysteresis for easy mode of parameter 2 group.

◎ Hysteresis mode [*H Y S M*]

- Set the hysteresis of pressure detection.
- Set the pressure detection level [*S t 1*, *S t 2*] and hysteresis [*H Y S 1*, *H Y S 2*].

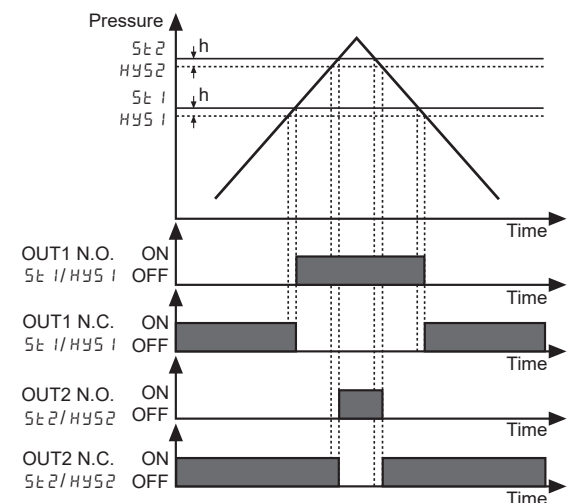

SENSORS

CONTROLLERS

MOTION DEVICES

SOFTWARE

(A) Photoelectric Sensors

(B) Fiber Optic Sensors

(C) LIDAR

(D) Door/Area Sensors

(E) Vision Sensors

(F) Proximity Sensors

(G) Pressure Sensors

(H) Rotary Encoders

(I) Connectors/ Connector Cables/ Sensor Distribution Boxes/ Sockets

Output Operation Mode

Window comparison output mode [WIN]

- It detects pressure at the desired range.
- Set high-limit value of pressure detection level [HI 1, HI 2], and low-limit value of pressure detection level [LO 1, LO 2].
- Hysteresis is fixed as Min. display interval.

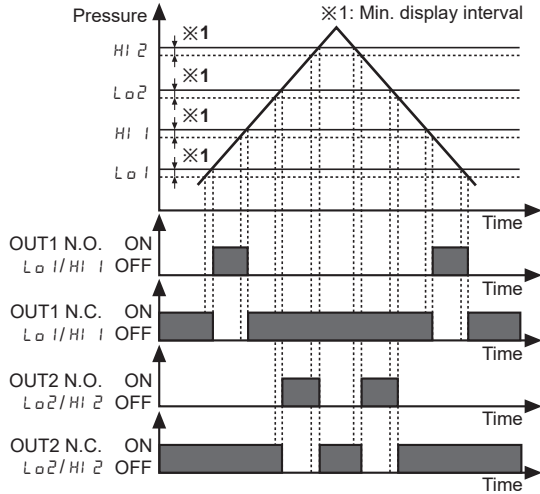

Auto sensitivity setting mode [AUTO]

- It sets the proper detection sensitivity automatically.
- It sets by the two pressure points [SE 1, SE 2].
- Hysteresis is fixed as Min. display interval.
- The pressure detection level [SEt] is shown in the below formula.

$$SEt = \frac{(SE1 + SE2)}{2}$$

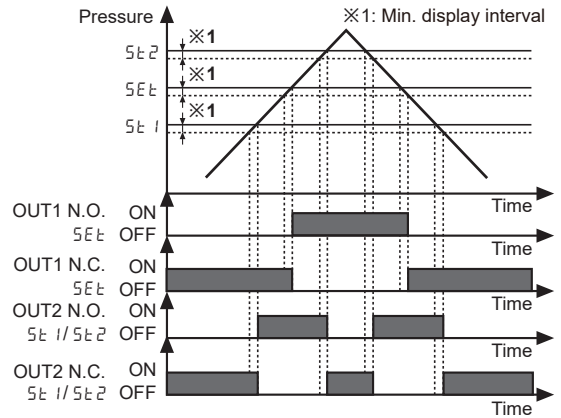

Forced output control mode [FOUC]

- Regardless of setting value, it maintains comparison output OFF and displays present pressure.
- Set OUT1 operation mode [OUT 1] of parameter 1 group as [FOUC] and return to RUN mode. The PV display part displays the measured pressure and the SV display part displays [FOUC].
- During forced output control mode, press the or key to turn ON/OFF OUT1, 2 manually.

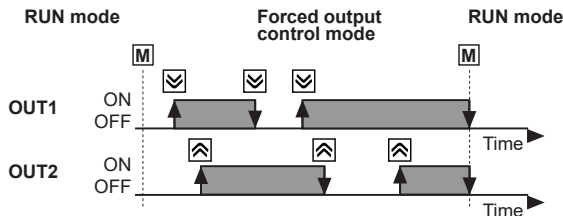
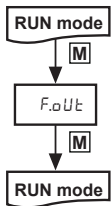

Compact, Dual LCD Display Digital Pressure Sensor

■ Functions

◎ Parameter copy

※ This function is for copying parameter settings of Master to Slave 1:1. Master and Slave should be the same specification model.

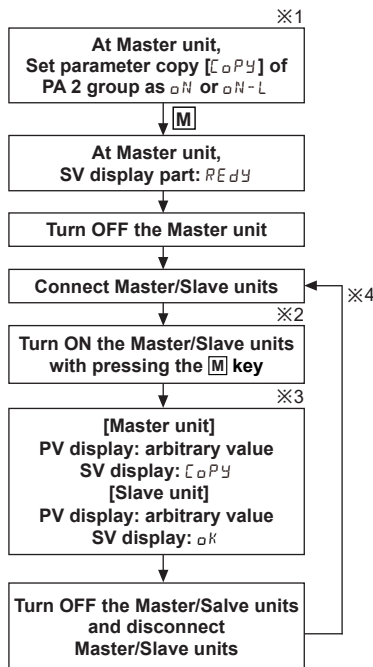
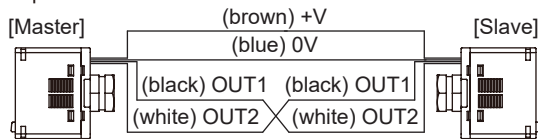

- ※1: ON: Copies SVs.,
ON-L: Copies SVs and locks front keys of Slave unit.
- ※2: When connecting Master unit and Slave unit incorrectly, the PV display of Master unit displays ERR4.
Turn OFF the Master unit power and turn ON it.
It displays REDY at SV display part.
- ※3: The PV display part of Master displays as orange color. The PV display part of Slave displays as green color. When completing copy, the PV display part of Master and Slave displays the same arbitrary value.
- ※4: Connect other Slave units to copy parameters.

◎ Analog output scale adjustment

※ only for NPN or PNP open collector output+ analog output or external input type

Set output voltage, output current to the current display value at 1-5VDC voltage output [A-V], DC4-20mA [A-I] current output.

- Set pressure value for 1VDC output [A-1V] and pressure value for 5VDC output [A-5V].
[A-1V] setting range: 0% F.S. ≤ [A-1V] ≤ 100% F.S.
[A-5V] setting range: 0% F.S. ≤ [A-5V] ≤ [A-1V]-10% F.S. or [A-1V]+10% F.S. ≤ [A-5V] ≤ 100% F.S.
- Set pressure value for 4mA output [A-04] and pressure value for 20mA output [A-20].
[A-04] setting range: 0% F.S. ≤ [A-04] ≤ 100% F.S.
[A-20] setting range: 0% F.S. ≤ [A-20] ≤ [A-04]-10% F.S. or [A-04]+10% F.S. ≤ [A-20] ≤ 100% F.S.

◎ Auto Shift/Remote Zero/Hold input

※ Only for NPN or PNP open collector output+ analog output or external input type

● Auto Shift [SHIFT], Remote Zero [ZER0]

When reference pressure of the pressure sensor changes, apply auto shift or remote zero digital input. It corrects present pressure to reference pressure and by moving detection level as much as fluctuation level. In case of remote zero, it is the same function as auto shift but remote zero makes the measured pressure as 0 forcibly. When changing analog output and external input setting, auto shift correction value [SHI N], remote zero correction value [ZEI N] are also reset as 0.

- Setting correction value
: Press the [M], [M] key to set SV manually or apply 0VDC to orange cable over 1ms.
When selecting analog output/external input [I/O] of parameter 1 group as [SHIFT] or [ZER0], press the [M] key to select control output at [SH.O], [ZE.O] to be with correction value.
- Deleting correction value
: Press the [M]+[M] keys for over 1 sec to delete set auto shift correction.

● Hold [HOLD]

The function to hold PV and control output while signal is input.

◎ Output mode change

● OUT1 operation mode

There are 4 kinds of control output mode in order to realize the various pressure detection.

- Hysteresis mode [HYSM]
: When needed to change hysteresis for detecting pressure.
- Window comparison output mode [WIN]
: When needed to detect pressure in certain area.
- Automatic sensitivity setting mode [AUT0]
: When needed to set detection sensitivity automatically at proper position.
- Forced output control mode [FOUT]
: When needed to display pressure with remaining comparison output OFF regardless of setting value.

● OUT2 operation mode

Select control output mode between two types or OFF.

- In case of OUT1 operation mode, select automatic sensitivity setting mode [AUT0] or forced output control mode [FOUT]. OUT2 operation mode setting is inactive.
- Hysteresis mode [HYSM]
: When needed to change hysteresis for detecting pressure.
 - Window comparison output mode [WIN]
: When needed to detect pressure in certain area.
 - OFF [OFF]

SENSORS

CONTROLLERS

MOTION DEVICES

SOFTWARE

(A) Photoelectric Sensors

(B) Fiber Optic Sensors

(C) LIDAR

(D) Door/Area Sensors

(E) Vision Sensors

(F) Proximity Sensors

(G) Pressure Sensors

(H) Rotary Encoders

(I) Connectors/ Connector Cables/ Sensor Distribution Boxes/ Sockets

PSQ Series

◎ Output type change

Output type for OUT1 and OUT2 can be able to set Normally Open or Normally Closed.

※Note that Normally Open and Normally Closed provide opposite output.

SV	OUT1 output	OUT2 output
$N\circ$	Normally Open	OFF
$N\bar{C}$	Normally Closed	OFF
$I\circ\bar{2}\circ$	Normally Open	Normally Open
$I\circ\bar{2}\bar{C}$	Normally Open	Normally Closed
$I\bar{C}\bar{2}\circ$	Normally Closed	Normally Open
$I\bar{C}\bar{2}\bar{C}$	Normally Closed	Normally Closed

◎ Response time (chattering prevention)

It can prevent control output from chattering by changing response time.

There are 10 types of response time; 2.5ms, 5ms, 10ms, 25ms, 50ms, 100ms, 250ms, 500ms, 1,000ms, 5,000ms. If the response time is getting longer, the detection will be more stable by increasing the number of digital filter.

◎ PV display color and color linked output

You can select PV display color to the linked output status. There are 4 types as below.

Select color linked output among $[O\bar{U}\bar{L}1]$, $[O\bar{U}\bar{L}2]$, or $[RLL]$.

SV	PV display color
$R\text{-}ON$	Green in normal status. When the set color linked output turns ON, it displays red.
$G\text{-}ON$	Red in normal status. When the set color linked output turns ON, it displays green.
REd	Red is fixed.
$GREN$	Green is fixed.

◎ Pressure unit change

PSQ series has 8 kinds of pressure unit.

Please select the proper unit for application.

• kPa, MPa, kgf/cm², bar, psi, mmHg, inHg, mmH₂O

※When using mmH₂O unit, multiply display value by 100.

◎ SV display part

Select the display type at the SV display part in RUN mode.

There are 3 types; displaying SV $[5\bar{L}d]$, displaying unit $[UNi\bar{L}]$, none $[OFF]$

◎ RESET

This function is to reset all parameters as factory default except control output SV to prevent wrong settings or difficult operation.

◎ Password

This function is to limit parameter settings, to check the parameter or to change the parameter settings only for entering the set password.

- 0000: Password function OFF
- 0001: Only checking parameters
- Setting range: 0002 to 9999

◎ Control output change

Select between NPN open collector output or PNP open collector output.

◎ Key lock

The key lock function prevents key operations so that conditions set in each mode.

- Press the $[M]+[OK]$ key over 1 sec in RUN mode to lock keys. The PV display part displays $[L\circ\bar{C}K]$, and the SV display part displays $[ON]$ for 1 sec and it returns in RUN mode.
- Press the $[M]+[OK]$ key over 1 sec in RUN mode to unlock keys. The PV display part displays $[L\circ\bar{C}K]$, and the SV display part displays $[OFF]$ for 1 sec and it returns in RUN mode.

◎ Zero-point adjustment

The zero-point adjustment function forcibly sets the pressure value to "zero" when the pressure port is opened to atmospheric pressure. When the zero adjustment is applied, analog output [Voltage or Current] is changed by this function.

To set zero atmospheric pressure forcibly, press the $[OK]+[ENT]$ keys over 1 sec in RUN mode with the opened pressure port.

◎ High/Low Peak Hold

This function is to diagnose malfunction of the system caused by parasitic pressure through memorizing input the max./min. pressure occurred from the system.

Press the $[M]+[ENT]$ key more than 1 sec in RUN mode and set the Peak Hold.

◎ Error and troubleshooting

Display	Cause	Troubleshooting
$ERR1$	When adjusting zero point while external pressure is input.	Try again after removing external pressure.
$ERR2$	When over current is applied on control output	Remove the over current conditions by adjusting load resistance.
$ERR3$	When the range of Auto sensitivity setting mode ST1, ST2 is set incorrectly.	Check the setting range and set $5\bar{L}1$, $5\bar{L}2$.
$ERR4$	When connection between master and slave is wrong during copying parameters.	Check the cables between sensors and the connection of the same models.
$ERR5$	When entering invalid password.	Enter valid password.
$HHHH$	When applied pressure exceeds the high-limit of display pressure range.	Apply pressure within the display pressure range.
$LLLL$	When applied pressure exceeds the low-limit of display pressure range.	
$-HH-$	When the correction value of auto shift, remote zero exceeds the high-limit of the setting range.	Set the correction value of auto shift, remove zero within the setting range.
$-LL-$	When the correction value of auto shift, remote zero exceeds the low-limit of the setting range.	
$-HL-$	When $[HH]$, $[LL]$ occur both.	

Compact, Dual LCD Display Digital Pressure Sensor

■ Installation

- Pressure port is divided as standard and option specification. Therefore, make sure use commercially available one touch fitting.
 - Pneumatic type: Rc1/8, R1/8, NPT1/8
 - Fluid type: Rc1/8, R1/8, R1/4, NPT1/4, 9/16-18UNF
- Use a spanner (pneumatic type: 12mm, fluid type: 17mm) at the metal part of the unit in order not to overload on the body when connecting one touch fitting.
- Two different brackets are provided for pneumatic type and one different brackets are provided for fluid type. Select proper one with considering your application environments.
- At first, please unscrew hexagon wrench bolt and assemble the bracket on this unit by fixing hexagon the wrench bolt.
In this case, tightening torque of hexagon wrench should be max. 3N·m. It may cause mechanical problems.

⚠ Caution

The tightening torque of one touch fitting should be max. 10N·m. It may cause mechanical problems.

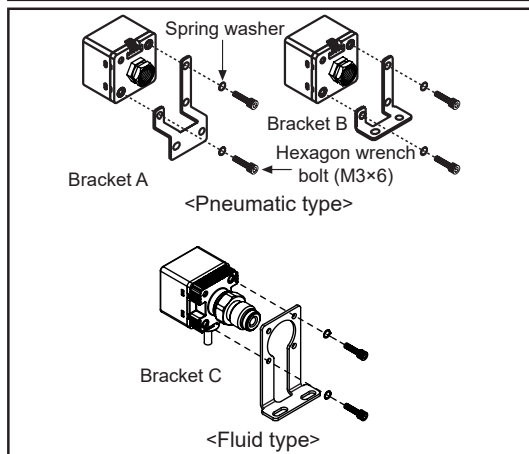
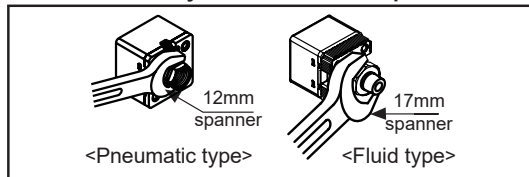

- PSQ Series has panel bracket (PSO-B02), front cover (PSO-P01) are sold separately. When mounting the unit on panel, please follow the below figure.

· When using integrated installation set

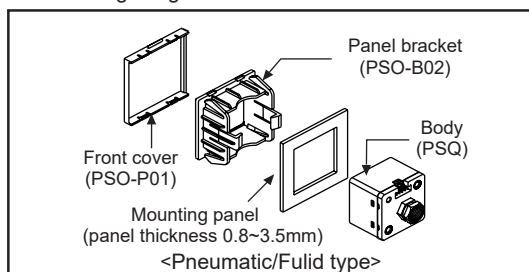

· When using separate installation set

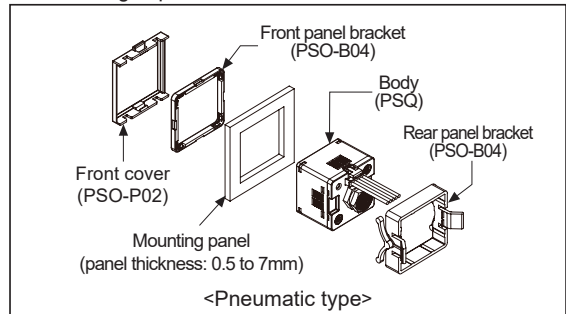

- Do not pull the cable with a tensile strength of 30N or over.

■ Proper Usage

⚠ Caution

PSQ Series is for sensing of non corrosive gas. Do not use this product at corrosive gas or flammable gas, etc.

- 12-24VDC model, power supply should be insulated and limited voltage/current or Class 2, SELV power supply device.
- Do not insert any sharp or pointed object into pressure port. Failure to follow these instructions may result in malfunction and damage to the sensor.
- Be sure that this unit must avoid direct touch with water, oil, thinner, etc.

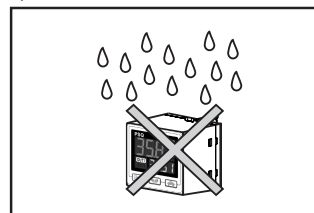

- Do not use the product in preparation time (within 3 sec.) for operating after power-on.
- When using switching mode power supply, frame ground (F.G.) terminal of power supply should be grounded.

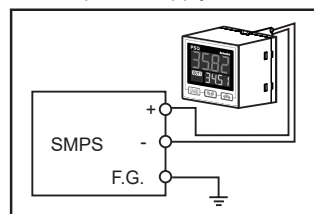

- Avoid wiring with power line or high voltage line. It may cause malfunction by noise.
- When moving this unit from cold place to warm place, please remove the humidity on the cover.
- Do not press the setting button with sharp or pointed object.
- Do not apply a tensile strength in excess of 30N to the cables or connector.
- This unit may be used in the following environment.
 - Indoors
 - Altitude max. 2,000m
 - Pollution degree 3
 - Installation category II

SENSORS

CONTROLLERS

MOTION DEVICES

SOFTWARE

(A) Photoelectric Sensors

(B) Fiber Optic Sensors

(C) LIDAR

(D) Door/Area Sensors

(E) Vision Sensors

(F) Proximity Sensors

(G) Pressure Sensors

(H) Rotary Encoders

(I) Connectors/ Connector Cables/ Sensor Distribution Boxes/ Sockets